

Specifications

MODEL GTH-3512

MEASUREMENTS	Metric	Imperial
Lifting height (max)	12.12 m	39 ft 9 in
Lifting capacity (max)	3,500 kg	7,715 lbs
Lift capacity at maximum height	2,500 kg	5,511 lbs
Lift capacity at maximum reach	1,000 kg	2,204 lbs
Forward reach (max)	8.53 m	28 ft
Reach at maximum height	1.17 m	3 ft 10 in
A Height	2.45 m	8 ft
B Height at steering wheel	1.84 m	6 ft
C Width	2.25 m	7 ft 5 in
D Inside cab width	86 cm	2 ft 10 in
E Track	1.85 m	6 ft 1 in
F Wheelbase	2.75 m	9 ft
G Length at front wheels	4.44 m	14 ft 7 in
H Length at fork-holder plate	5.75 m	18 ft 10 in
I Ground clearance	43 cm	1 ft 5 in
L Overall width, stabilisers extended	2.93 m	9 ft 7 in
M1 Obstruction angle	37°	37°
M2 Departure angle	39°	39°

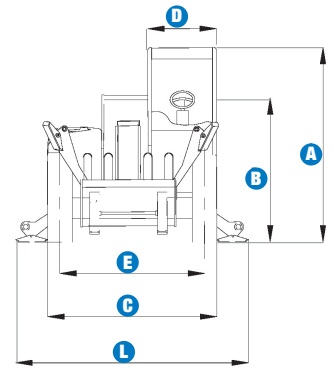
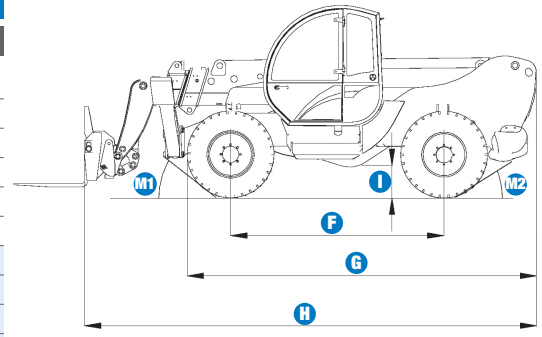

PRODUCTIVITY

Lifting/lowering speed	13 sec./ 8 sec.	13 sec./ 8 sec.
Extension/retraction	20 sec./ 24 sec.	20 sec./ 24 sec.
Inside/outside turning radius	2.42 m/4.5 m	7 ft 11 in/ 14 ft 9 in
Break-out force (with 500 L shovel SAE J 732/80)	4,500 kg	9,920 lbs
Towing capacity at dynamometer	8,200 kg	18,076 lbs
Travel speed	30 km/h	18.6 mph
Fork-holder plate rotation	145°	145°
Floating forks	Length 1200 mm Section 120x45mm	Length 3 ft 11 in Section 5 in x 1.77 in
Tyres (DIN 70361)	405/70-20" PR16 8 holes wheel disc	

POWER

Engine	Deutz Turbo Diesel 60 kW (81.5 hp)	
Tank capacities		
Fuel	92 L	20 gal
Engine oil	8 L	1.75 gal
Hydraulic oil	90 L	19.8 gal
Hydraulic output/pressure	82 L/min-280 bars	18 gal/min-4,061 psi

WEIGHT

Weight*	9,000 kg	19,840 lbs
---------	----------	------------

STANDARDS COMPLIANCE

Operating cab conforms to ISO3471 (ROPS) and ISO3449 (FOPS)
Low emission engine conforms to UE 97/68 directives.

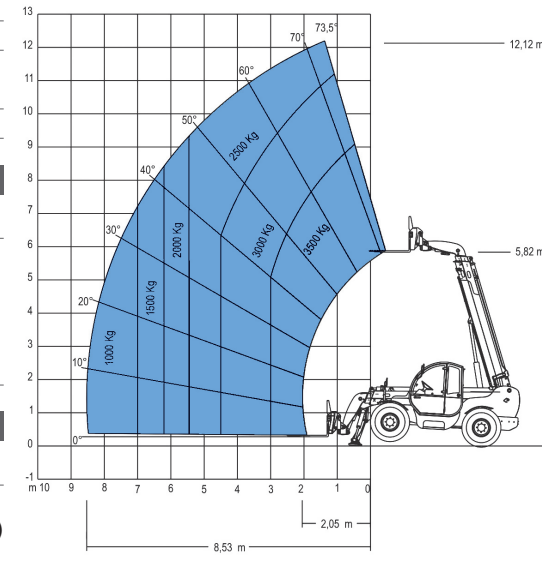

Lift capacity chart (with stabilisers)

EN1459, Annex B

* Weight will vary depending on options and/or country standards

Features

STANDARD FEATURES

MEASUREMENTS

- 3,500 kg (7,715 lbs) maximum lift capacity
- 12.12 m (39 ft 9 in) maximum lift height
- 8.53 m (28 ft) maximum forward reach

PRODUCTIVITY

- Four-wheel drive
- 3 steering modes:
 - front wheel steer
 - crab steer
 - coordinated steer
- Power assisted steering
- Front hydraulic stabilisers
- Two-speed mechanical gearbox
- Hydraulic proportional distributor
- Multifunction proportional joystick hydraulically piloted
- Limited slip differential on front axle
- Floating forks
- Adjustable suspended seat
- Large diameter steering wheel
- Front windscreen wipers
- Front & rear lights
- Oil immersed, multi-disc, self adjusting brakes on both axles
- Lockable fuel tank
- Longitudinal stability control system with load monitor
- Visible display with coloured LEDs
- Audible alarm
- Automatic lock-out of boom extension and lowering
- Control enable switch

POWER

- Deutz Turbo Diesel 60 kW (81.5 hp)



OPTIONS & ACCESSORIES

PRODUCTIVITY

- Air conditioning
- Hydraulic line on boom
- Attachment holder plate with hydraulic coupling
- Quick coupling for attachments
- Electric pre-arrangement on boom
- Pre-arrangement for mixing bucket
- Second hydraulic line on boom
- Special air filter
- Windshield protection grid
- Adjustable spotlight
- Wiper on cab roof

ATTACHMENT OPTIONS

- Loading shovel 800 L
- Light material loading shovel 2000 L
- Concrete bucket 500/800 L manual/hydraulic discharge
- Concrete mixing bucket 500 L with remote control
- Brick-holder basket
- Fixed hook on plate
- 4 m jib, 900 kg capacity
- 4 m jib with 900 kg capacity hydraulic winch
- Hydraulic winch 3000 kg
- Water muffler

European Offices

UK

The Maltings
Wharf Road
Grantham NG31 6BH
UK
Tel: +44 (0)1476 584333
Fax: +44 (0)1476 584334

France

10, ZA de la Croix St. Mathieu
28320 Gallardon
France
Tel: +33 (0)2 37 26 09 99
Fax: +33 (0)2 37 26 09 98

Germany

Finienweg 3
28832 Achim/Bremen
Germany
Tel: +49 (0)4202 8852-0
Fax: +49 (0)4202 8852-25

Spain

Gaià 31, Pol. Ind. Plà d'en Coll
08110 Montcada i Reixac
Barcelona
Spain
Tel: +34 93 572 50 90
Fax: +34 93 572 50 91

Scandinavia

Tagenevägen 72
425 37 Hisings Kärra
Sweden
Tel: +46 31 57 51 00
Fax: +46 31 57 90 20

Genie United States

18340 NE 76th Street
P.O. Box 97030
Redmond, Washington 98073-9730
USA
Tel: +1 425 881-1800
Fax: +1 425 883-3475

WEB: www.genieindustries.com
Email: infoeurope@genieind.com

Distributed By: